

Internet de las Cosas

Prácticas RFID



Rogelio Ferreira Escutia

Profesor / Investigador
Tecnológico Nacional de México
Campus Morelia



Arquitectura

RFID

- **Arquitectura:**

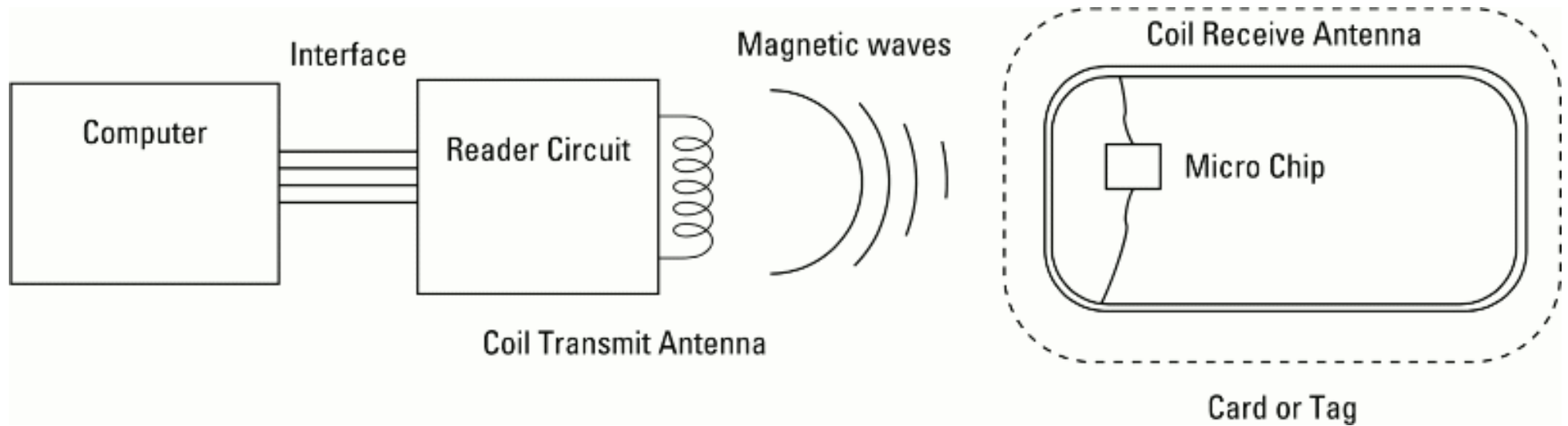

RFID

- **RC522:**

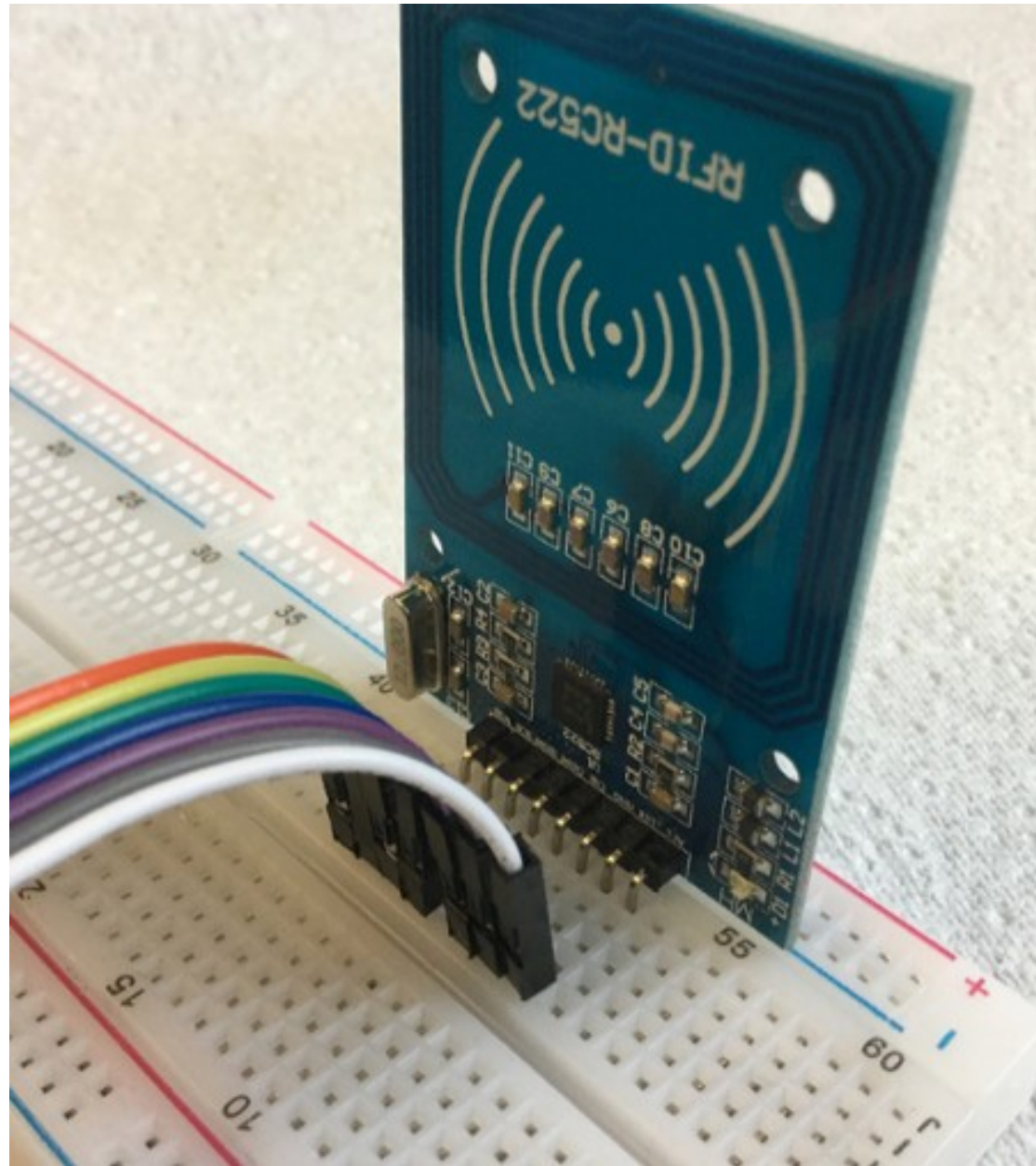

RFID

■ Conexión::

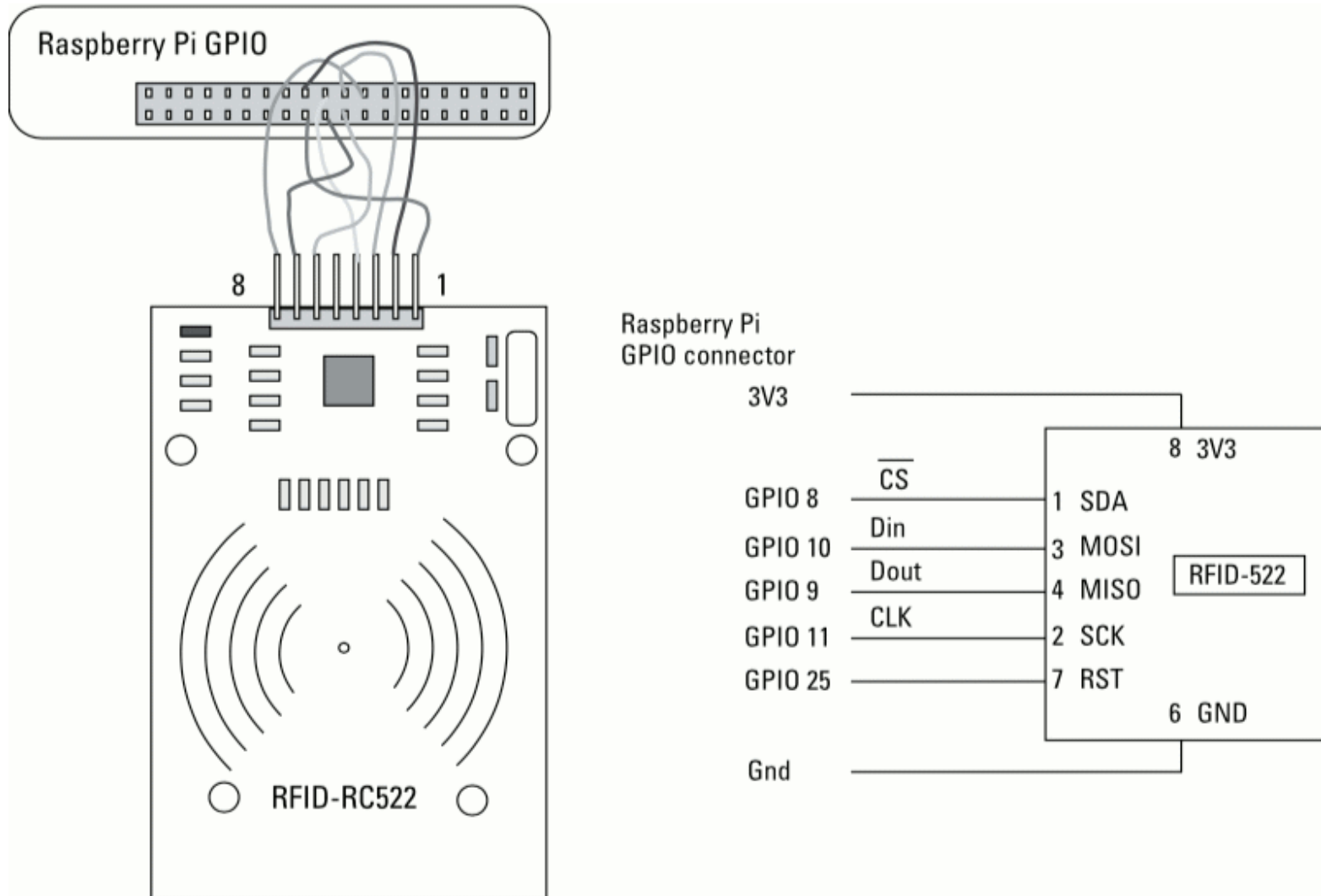

Instalación de Software

Librería SPI-py

- **Instalación:**

```
git clone https://github.com/lthiery/SPI-Py.git
cd SPI-Py
sudo python setup.py install
sudo python3 setup.py install
```

Lectura del RFID

RFID 13.56 MHz (MIFARE)

- **Formato de datos almacenados:**

```
Sector 0 [203, 58, 164, 213, 128, 8, 4, 0, 98, 99, 100, 101,
          102, 103, 104, 105]
Sector 1 [0, 0, 0, 0, 0, 0, 0, 0, 0, 0, 0, 0, 0, 0, 0]
Sector 2 [0, 0, 0, 0, 0, 0, 0, 0, 0, 0, 0, 0, 0, 0, 0]
Sector 3 [0, 0, 0, 0, 0, 0, 255, 7, 128, 105, 255, 255, 255,
          255, 255, 255]
Sector 4 [0, 0, 0, 0, 0, 0, 0, 0, 0, 0, 0, 0, 0, 0, 0]
Sector 5 [0, 0, 0, 0, 0, 0, 0, 0, 0, 0, 0, 0, 0, 0, 0]
Sector 6 [0, 0, 0, 0, 0, 0, 0, 0, 0, 0, 0, 0, 0, 0, 0]
Sector 7 [0, 0, 0, 0, 0, 0, 255, 7, 128, 105, 255, 255, 255,
          255, 255, 255]
Sector 8 [0, 0, 0, 0, 0, 0, 0, 0, 0, 0, 0, 0, 0, 0, 0]
Sector 9 [0, 0, 0, 0, 0, 0, 0, 0, 0, 0, 0, 0, 0, 0, 0]
Sector 10 [0, 0, 0, 0, 0, 0, 0, 0, 0, 0, 0, 0, 0, 0, 0]
Sector 11 [0, 0, 0, 0, 0, 0, 255, 7, 128, 105, 255, 255, 255,
           255, 255, 255]
```

RFID 13.56 MHz (MIFARE)

- **Código para lectura de datos:**

```
#!/usr/bin/python3
# Token reader by Mike Cook

from rc522rfid import Rc522rfid

rfidReader = Rc522rfid()

print ("Card token reader")
print ("Press Ctrl-C to stop.")
while 1: # repeat forever
    cardNumber = rfidReader.RC522_GetCard()
    print(hex(cardNumber))
```

Kits de RFID

RFID - Kits

- **Lectora y tarjetas RFID**



RFID - Lectora

- Lectora RFID-RC522



RFID

- Soporte para protoboard

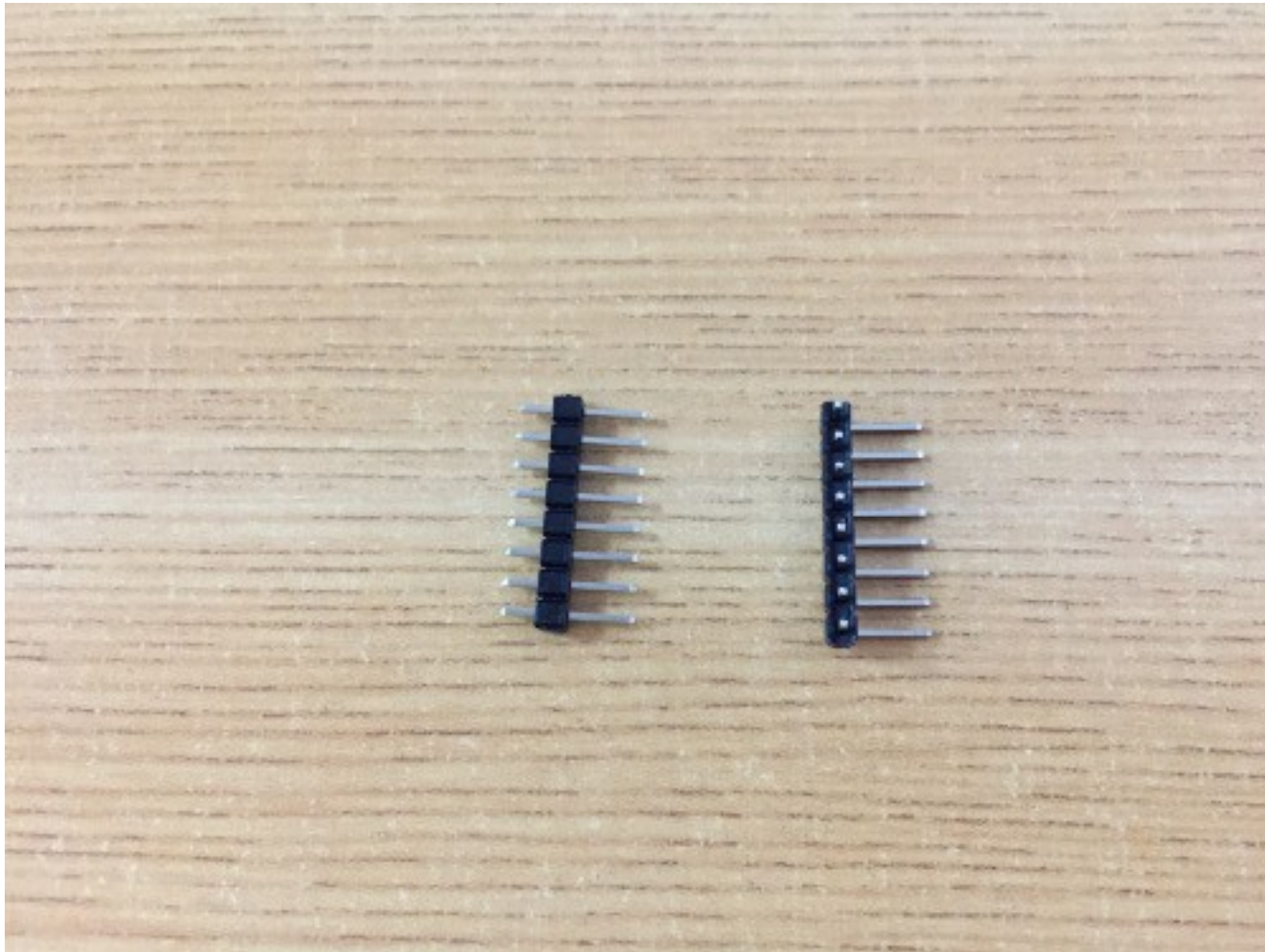

RFID - Tarjetas

- **Tarjeta RFID**



RFID - Tarjetas

- **Tarjeta RFID tipo llavero**





Rogelio Ferreira Escutia

Profesor / Investigador
Tecnológico Nacional de México
Campus Morelia



rogelio.fe@morelia.tecnm.mx



rogeplus@gmail.com



xumarhu.net



[@rogeplus](https://twitter.com/rogeplus)



[https://www.youtube.com/
channel/UC0on88n3LwTKxJb8T09sGjg](https://www.youtube.com/channel/UC0on88n3LwTKxJb8T09sGjg)



[rogelioferreiraescutia](https://www.linkedin.com/in/rogelioferreiraescutia)

